



Distribution Transport. The Actros. The Arocs.

Mercedes-Benz

Trucks you can trust.



Mercedes-Benz. Trucks you can trust.

The logo for the Mercedes-Benz Actros truck, featuring the word "ACTROS" in a bold, italicized, metallic font with a blue-to-silver gradient.The logo for the Mercedes-Benz Arocs truck, featuring the word "AROCS" in a bold, italicized, metallic font with a blue-to-silver gradient.

Mercedes-Benz. This name stands for all the experience of the world's longest established and most highly reputed truck manufacturer and for pioneering vehicle technology. A rich fund of engineering expertise "made in Germany" is reflected in particularly reliable, efficient, safe and robust vehicles in which millions of customers worldwide place their trust. We also attach great importance to a trusting relationship, with the aim of making life easier for you as a transport operator. To this end, we offer individual, application-matched vehicle solutions which meet the highest standards in terms of reliability, efficiency, safety and robustness, as exemplified by the new Actros and Arocs. See for yourself! Trucks you can trust.

The new Actros. The new truck designed for operations with a primary emphasis on medium to long-distance distribution and line-haul applications. Its great strengths include: reliability, efficiency and safety.

The Arocs. The truck designed for distribution applications ranging from 18 t to 33 t heavy duty distribution. Its great strengths include: reliability, safety and robustness.

RoadEfficiency 4

Reliability 5 - 9

Efficiency 10 - 14

Greater Safety 16 - 17

Robustness 19

Parts 21 - 22



Honed for efficiency on every level.

The new Actros and Arocs is the result of an all-embracing approach which we refer to as RoadEfficiency. As such, it meets all the requirements for even more efficient transport better than ever before.

RoadEfficiency. In the past we promised you low total costs – and we kept our promise. Now we are promising you even more comprehensive efficiency. With the Actros and Arocs. In addition to particularly low total costs and high reliability, it boasts in particular assistance systems for enhanced driving safety, a further increase in vehicle usage and, last but not least, high standards of driving comfort, ergonomics and living comfort.

Low total costs. This is the first pillar of RoadEfficiency and a promise that the Actros and Arocs bears out by virtue of lower fuel consumption than its predecessor. This is thanks to its further optimised aerodynamics and enhanced Predictive Powertrain Control.

Greater safety. This is the second pillar of RoadEfficiency and an attribute of our trucks to which the Actros and Arocs attaches even greater emphasis.

Maximised use. The third pillar of RoadEfficiency comprises the service innovation Mercedes-Benz Uptime and other pioneering advantages of the Actros. In addition to simpler handling and work procedures, these also include the intelligent networking of driver, vehicle and logistics processes, which enables noticeable improvements in vehicle use and capacity utilisation.

Reliability. The Actros and Arocs is a truck that bears out the promise “Trucks you can trust”. With application specific, durable engineering and technology, for example, and with the wealth of experience that comes from more than 120 years in vehicle manufacturing.

Low total costs

+ Greater Safety

+ Maximised use

RoadEfficiency
is the sum of
the detail

Reliability - giving you that extra edge. It stands for a tradition extending back over more than 120 years.

During the construction of our trucks, we always use the strictest quality standards: Real-life requirements. Or in short: Your requirements.

Trucks you can trust – for more reliability.

Reliability. For us, this means providing you with trucks that operate without a hitch, even in extreme conditions and in difficult terrain. In other words: “Trucks you can trust”. As your partner who helps you to master your daily transport tasks efficiently, we will continue to put our all into ensuring you have reliable vehicles at your disposal. With the wealth of experience that comes from more than 120 years in vehicle manufacturing. With trucks boasting robust components that have been tried and tested thousands of times and equipment designed to cope with the topographic and climatic conditions that prevail where the vehicles are to be operated. This applies to engines, gearshifts, transmissions and drive axles as well as frames, chassis, suspension and cabs, as a reliable truck can only ever be the sum of its reliable individual components. Tailored perfectly to practical requirements.

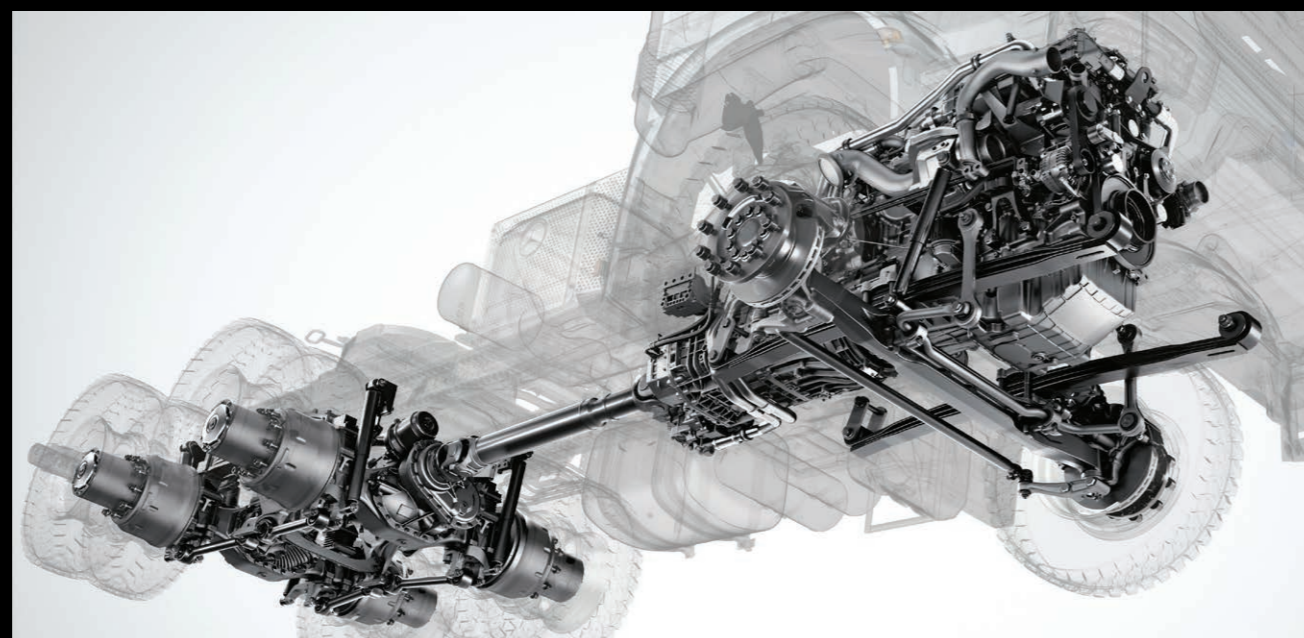

Powertrain. In order to meet all the given high requirements regarding durability and reliability, all components of the powertrain on Mercedes-Benz Trucks are ideally matched – and produced exclusively by Mercedes-Benz.

Tested to the highest standards: yours.

From the windscreen wiper to the brake lamp – at Mercedes-Benz, reliability is built-in as standard. This comes from a recognition that every component is important – right from the design and development stage.

Reliable engines. All engines offer a particularly robust, durable design, a high degree of reliability and an extended service life. The high robustness of the 6-cylinder in-line engines results from optimised engine cooling and design measures such as one-piece steel pistons, reinforced conrods and bearings and a more rigid crankcase, for example. In addition, the wide torque curve reduces the number of gearshift operations and thus lowers the strain on the clutch and transmission.

Powertrain. All components of the drivetrain are perfectly matched and produced exclusively at Mercedes-Benz. With its sensitive gearshift sensors, Mercedes PowerShift 3 provides precise gear selection appropriate to the driving situation and the given load. Excellent frictional connection is ensured by 1- or 2-disc clutches which are designed for torque levels up to a massive 3000 Nm. The robust, weight-optimised drive axles designed for an axle load of up to 16 t ensure that the engines' vast power is converted virtually undiminished into propulsive power, thereby also saving fuel.

Frame, chassis, suspension. Road and construction site use impose different requirements on the frame, chassis, suspension and brakes. Accordingly, our trucks are equipped with precisely the components required for the job in hand. Optimum application specification is ensured by different frame widths and thicknesses, long service lives and a high standard of reliability. Suitable suspension variants are also available to match the job in hand – steel, or steel/air suspension. Reliable braking performance is ensured either by disc brakes or drum brakes.

Extended service life. Anti-corrosion protection for the cabs through the use of galvanised panels, robust frames protected from corrosion by means of cathodic dip priming, a transmission oil cooler for reduced thermal stress, efficient air filters and long maintenance intervals are all factors that contribute to a high level of reliability.

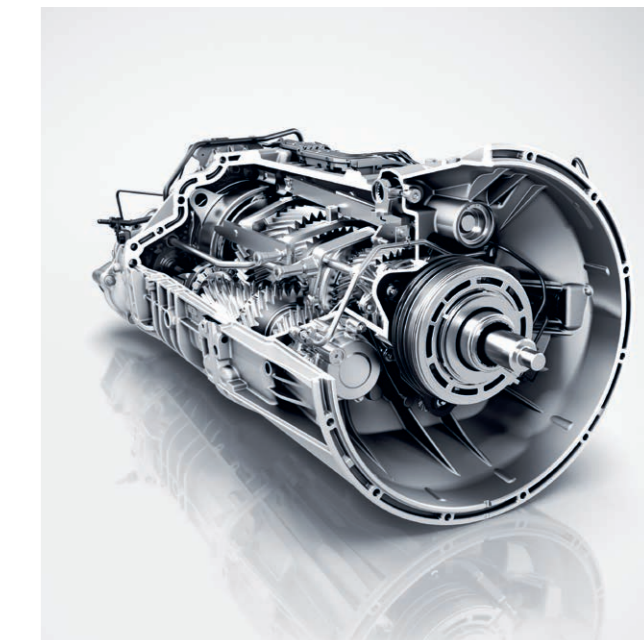

Transmissions for every application. The transmission performs fast gear changing. The generous installation space means that it is also possible to use wide gearwheels. This enables high levels of torque to be transferred.

Brakes. Depending on the type of deployment, for a high standard of safety we equip the trucks either with disc brakes or drum brakes. The high power of the engine brake and retarder boost the available braking power, reduce wear and improve economic efficiency.

Suspension variants. The Actros and Arocs always offers the suspension variant which is best suited for the given type of application – steel or steel-air suspension.

Extensive testing. All Actros and Arocs components are engineered to be particularly durable, repair- and maintenance-friendly and boast a high degree of reliability. This is further ensured by extensive testing at the Mercedes-Benz Development and Testing Centre in Wörth, where worldwide road conditions are simulated, enabling our trucks to be tested under the toughest conditions. The unrelenting test programme also includes summer and winter trials at extreme temperatures and millions of kilometres on rough road tracks and in endurance testing. Overall, the Actros has demonstrated its durability and reliability over more than 60 million test kilometres.



High-quality production. With more than 120 years of experience in truck production, premium Mercedes-Benz quality is assured at every step of the production process to guarantee maximum reliability.

Advantages at a glance

- 6-cylinder in-line engines which are particularly reliable, efficient and durable
- Finely coordinated drivetrain configurations in particularly robust design offering extended service lives
- Mercedes PowerShift3 for easy operation, reduced shift times, precise gear selection and fuel savings
- 1- or 2-disc clutches for maximum torque of up to 3000 Nm and for high gross combination weights
- Efficient hypoid axles and robust planetary axles for high axle loads
- Extensive testing and high-quality production process guarantees that every truck earns its star
- Application specific axles as well as frame, chassis, suspension and brake components
- Increased cooling capacity for engine and transmission
- Long maintenance intervals and service-oriented design for lower repair and maintenance cost



Efficiency - Economical to the core.

The new Actros stands for reliable, fuel-saving vehicle technology, lower costs and higher profitability. In a nutshell: greater efficiency.

The Actros – for more efficiency. In addition to its reliable and durable design, efficiency is another core characteristic of the Actros, based first and foremost on its particularly low fuel consumption. Low wear and a higher resale value are additional merits contributing to its high overall efficiency. To this end, numerous innovative technical measures were implemented in the course of developing the Actros and Arocs. These result in engines with high performance and lower fuel consumption, a powertrain which enables an economical driving style, and an aerodynamic design honed down to the finest details in the interests of fuel efficiency. Fuel-saving drive programs, an optimised rear axle ratio also contribute to the low fuel consumption. Intelligent ancillary consumers and finely honed aerodynamics also play a role. The further advanced Mercedes PowerShift 3 automated gearshift combines

an economical driving style with smooth gear changing and a high level of driving comfort. The application-matched and aerodynamic cabs of the Actros and Arocs also contribute to the high level of efficiency. In short, the Actros offers you a vehicle which is tailored perfectly to the needs of practically any application. Climb aboard!

Sophisticated aerodynamics. We have further improved the aerodynamics of the Actros to achieve an extremely low level of drag and even lower fuel consumption.



This system provides for a particularly homogeneous fuel-air mix and especially efficient combustion. This results in more power combined with particularly low fuel consumption.

Never be satisfied with less. Except when it comes to fuel consumption.

The lower your fuel consumption, the lower your overall costs. With this in mind, we have given our all to reduce fuel consumption as standard on the new Actros.

Low on fuel, high on efficiency. The Actros and Arocs with its 6-cylinder in-line engines is a particularly economical proposition. The three engine types (OM460, OM471 and OM473) are available in the two displacement classes, 12.8 l and 15.6 l and power output ratings from **265 kW (360 hp)** to **460 kW (625 hp)**. With the OM471 and OM473, the combination of low fuel consumption and improved performance is attributable to the particularly efficient combustion strategy, the X-Pulse common rail high-pressure injection system with an injection pressure of up to 2700 bar and the patented asymmetric turbocharger. Further factors contributing to fuel savings are the more fuel-efficient auxiliary consumers, Mercedes PowerShift3 and the sophisticated aerodynamic design.

Mercedes PowerShift3. Precise gear selection and fast gear-changing ensure that the further advanced Mercedes PowerShift3 automated gearshift transmits the power spontaneously and efficiently to the rear axle. This is possible thanks to an improved shifting strategy that accounts for factors such as gross combination weight, inclination angle of the road and accelerator pedal position

when selecting the optimum gear. In addition, short shift times, further friction reduction and the “economy” driving programmes also support an economical driving style. Further benefits include the option of shifting directly from 1 to R, reverse gears with high ratios, the crawl function and EcoRoll.

Brakes. In addition to the proven electronic braking systems with disengageable ABS, ASR, Brake Assist and hill holder, powerful, wear-free engine brakes provide added safety. The wear-free continuous High Performance Engine Brake is available on Actros and Arocs models. This three-stage brake system offers up to **475 kW** of braking power²⁾ and reduces wear on the service brake while enhancing safety and control of the vehicle. For even greater safety, the new Actros and Arocs is equipped with the new, high-performance secondary water retarder¹⁾. This retarder is wear- and maintenance-free and offers increased braking power, higher average speeds on downhill stretches and less weight than conventional oil retarders.

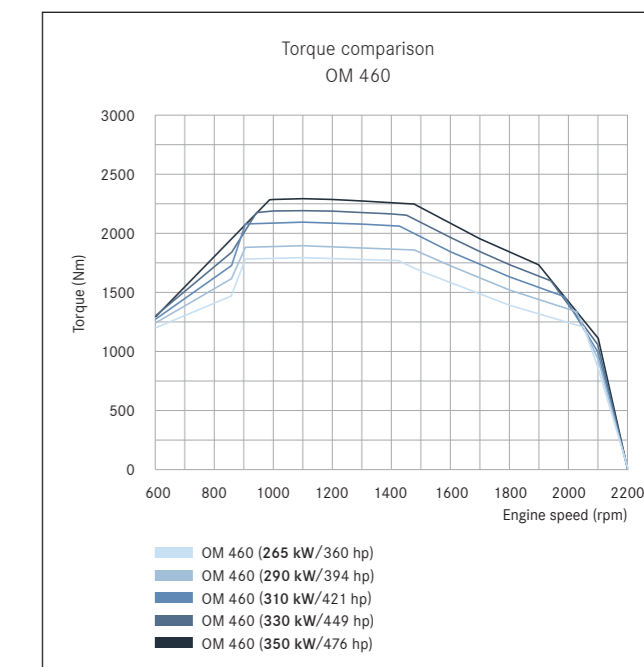

More power – less fuel. From **265 kW** (360 hp) to **350 kW** (476 hp) the OM460 engines make their maximum torque available in the lower, fuel-efficient engine speed range.

Lower costs, higher efficiency.

Axles and auxiliary consumers. A wider choice of rear axle ratios matched to various operating profiles also plays a role in keeping fuel consumption low. Economical auxiliary consumers, such as the on-demand power steering pump and new air-conditioning unit also contribute to low fuel consumption.

Aerodynamically efficient. The design of the Actros and Arocs has been optimised right down to the finest details in order to reduce wind resistance. Engineers even developed a special cab variant with aerodynamically-optimised design and therefore low fuel consumption: the StreamSpace cab. Features such as the door extensions and aerodynamic wind deflectors¹⁾ also save fuel.

1) Available on certain models
2) Dependent on engine variant



Two-stage air compressor. The fuel-efficient air compressor with two-stage compression is just one of many factors contributing to the Actros's low fuel consumption. Low weight and high reliability are additional benefits.



Sophisticated aerodynamics. When designing the Actros we tested every individual part extensively. In the wind tunnel and on many million miles of test routes – for minimal drag and low fuel consumption.

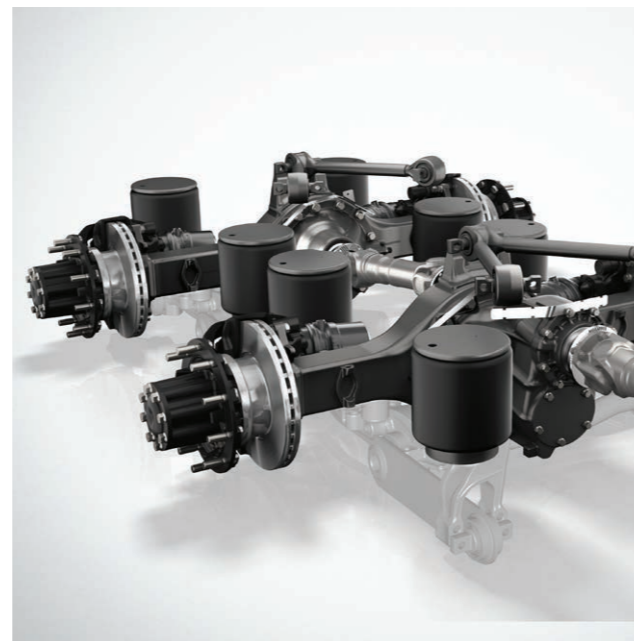

Hypoid twin axles. The further advanced hypoid twin axles contribute to low fuel consumption on the Actros. In addition, a broad range of rear axle ratios is available for fuel-efficient powertrain configurations.

Your workplace in the Actros and Arocs.

Solutions geared to practical needs provided the terms of reference in developing the new workplace, resulting in a whole array of components which are finely matched on both an ergonomic and functional level. These include the new cockpit, seats and the new multifunction steering wheel. Everything can be operated intuitively and is precisely tailored to the driver's work procedures. The attractive colour concept, the high-quality materials and the developed beds are further assets providing that extra touch of work motivation.

Optimum application matching. As your experienced partner who understands your needs, we offer you an individual, business-oriented vehicle solution for every transport task. The Actros and Arocs offers the ideal basis for long-distance applications. When the emphasis is on heavy duty distribution applications, the Actros and Arocs has a range of trucks specifically designed for distribution transportation.



State-of-the-art workplace. The newly designed workplace, with a cockpit that is ideally suited to the driver's needs, offers optimum working conditions, because everything is arranged ergonomically and within easy reach. From switches and stowage compartments in the dash support to the gearshift, which is now operated via the steering-column lever. The multifunction steering wheel can be adjusted via a foot-operated switch, and moved to a virtually vertical position for getting in and out. In short: everything ensures that drivers can concentrate on their work in a relaxed manner.

Advantages at a glance

- Up to 6% less fuel consumption
- New, reliable, robust and efficient 6-cylinder in-line engines
- Mercedes PowerShift 3 with application-driving programs for fast shift times and a perfect shifting strategy
- Optimized hypoid axles ideally matched to the vehicle application for an even more fuel-efficient powertrain configuration.
- Aerodynamic cabs for low wind resistance and minimal consumption
- Optimized auxiliary consumers
- High level of safety thanks to numerous assistance and safety systems
- State-of-the-art driver workplace

Keeping business rolling. With optimum vehicle usage.

Mercedes-benz Uptime. Mercedes-Benz Uptime is a revolutionary teliagnosis operating system. It can monitor various sensors on your vehicle in real time without the need for a manual link and download, and can provide guidance on actions to ensure optimal vehicle availability. Mercedes-Benz Uptime can detect critical conditions related to sensor readings at an early stage. Data is shared automatically with Mercedes-Benz so we can alert you to anything that needs attention, providing appropriate repair solutions in good time.

Mercedes-Benz Service24h: Assistance around the clock. Mercedes-Benz Service24h ensures direct

assistance in the event of a breakdown – 365 days a year and 24 hours a day. A call to the free 1) hotline on 0800 133 355 is all it takes. If the driver also presses the “Service Call Button”, the vehicle data and the coordinates of the breakdown location are transmitted to Mercedes-Benz Service24h. In the event of a breakdown, excellently equipped service technicians arrive at the scene with a workshop on wheels to get the vehicle up and running again as quickly as possible.

Fleetboard. Driver and Vehicle Telematics Management System. FleetBoard offers objective and comparative data from each freight vehicle in the fleet, which provides an overview of the operational performance of individual

vehicles, fuel levels, and consumption, as well as drivers work profiles, by means of evaluations and grading’s, ensuring optimal flexibility, maintenance and service information. Driver and vehicle management entails performance analysis, service/telediagnosics, trip records and mapping.

Mercedes-Benz TruckTraining Driver development is of significant importance in the transport industry as latest technology on modern commercial vehicles requires upgraded driver skills. Mercedes-Benz TruckTraining provide tailor made courses and programs to achieve this goal. Customers benefit from optimal utilization of the vehicle and improved efficiency of their fleets.



Mercedes



Service24h



Fleetboard

Financing and Buy-back solutions.

Mercedes-Benz Financial Services. Who better to finance your truck than the people who built it? Whether you own one commercial vehicle or a fleet, having the right financial partner by your side is critical. That’s why Mercedes-Benz finance, is dedicated to providing flexible terms and financing options that are every bit as attractive as your Mercedes-Benz. Powerup your finance solutions with Mercedes-Benz value chain, working in harmony to convoy you to financial success. Mercedes-Benz Financial Services South Africa is 100% owned by Mercedes-Benz South Africa, and thus the Finance and Insurance arm of the group of companies. As an Independant Captive Funding House, Mercedes-Benz Finance is focussed on all the commercial vehicles in the MBSA stable of brands. Not only financing the vehicle but also assist with the finance of additional items on the unit as well as trailers. We are geared on client satisfaction and committed to offering tailor made mobility solutions.

Truckstore. We buy, sell and love used trucks. The international TruckStore network that provides accessto a unique pool of trucks of all brands, ages and types. From used tractor units to trailers. TruckStore offers warranty, leasing, finance, buy-back services.



Residual value. When you choose our trucks, you can count on vehicles whose innovative technology and task-optimised vehicle configurations mean you can look forward to a particularly high residual value. This is an important consideration for every truck operator because the higher a truck’s residual value is at the end of its period of use, the lower its depreciation is while it is in service.



Safety is at the root of our DNA.

Arrive safely – with the support of innovative assistance systems to improve driving safety which actively relieve the strain on the driver and treat the vehicle and the load with sufficient care, thereby contributing to higher efficiency. On every journey.

Greater safety. Trucks that are very safe are not just an important development for all road users. They are also more efficient, because they are less often put out of action by accidents and they relieve the driver's workload. This is why we have been focusing for over 45 years now on developing innovative assistance systems.

Active safety equipment. Mercedes-Benz employs many safety and assistance systems to reduce risks and ease the burden on the driver. Alongside the Electronic Braking System with ABS, ASR, hill holder and Active Brake Assist 5¹⁾, the Stability Control Assist system, Lane Keeping Assist and Attention Assist help the driver to avoid or mitigate accidents. Also contributing to the high level of safety are the standard LED day-time running lights, LED tail-lights and flashing hazard warning lights under emergency braking

Passive Safety. The Actros and Arocs offers the most comprehensive active safety systems ever. However, not all accidents can be fully prevented. For this reason the Actros and Arocs provides a passive safety concept developed through rigorous crash tests. The cab has been tested according to ECE R29 and Swedish Test VVFS: 2003:29. The target of these tests is a distribution of the

deformation, which results in the greatest possible clearance for the occupants. Furthermore, the driver airbag and driver seatbelt monitor are standard features on all Actros models, enhancing driver safety.

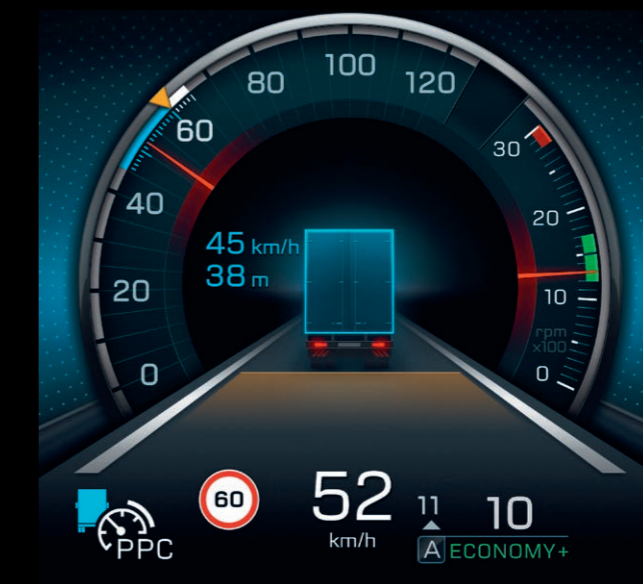

Proximity Control Assist¹⁾. The safety system with stop-and-go function is on hand to support the driver in stressful situations and can reduce the risk of rear-end collisions.



Attention Assist. Monitors the attention paid by the driver. It is based on the Lane Keeping Assist system. The attention paid by the driver is measured on the basis of the driver staying in-lane, in combination with various driver activities (direction indicator/accelerator/engine brake/retarder operation, etc.) as well as steering behaviour.

Active Brake Assist 5¹⁾. The fifth generation of the system assists the driver^{2) 3)} by carrying out full brake application in response to stationary and moving objects in certain conditions, in addition to which it is also able to perform partial or maximum full-stop braking in response to moving or halted pedestrians, thereby reducing the severity of accidents or avoiding accidents altogether.

Electronic Parking Brake. It is activated automatically on switching off the engine, but can also be switched on and off using the lever in the cockpit. The integrated HOLD function is activated when the vehicle is at a standstill simply by pressing the brake pedal more firmly, for example

at a red traffic light or on an uphill gradient. It is released as soon as the accelerator is pressed again. This avoids the danger of the vehicle rolling back when moving off on an uphill gradient.

Secondary water retarder. The secondary water retarder¹⁾ is wear- and maintenance-free and offers increased brake power, higher average speeds on downhill stretches and less weight than conventional oil retarders.

- 1) Available on certain models.
- 2) Within the system's limits.
- 3) Under optimal conditions.



Active Brake Assist 5¹⁾. By carrying out full brake application, it can reduce the severity of accidents or even prevent them completely.



LED day-time running lights. Safety is further enhanced by the standard LED day-time running lights. This also makes the vehicle more visible to other road users.

Advantages at a glance

- Comprehensive scope of safety equipment, incl. Active Brake Assist, Stability Control Assist, Lane Keeping Assist, Attention Assist¹⁾
- Proximity Control Assist with stop-and-go function and Active Brake Assist 5¹⁾, electronic parking brake with HOLD function
- Secondary water retarder¹⁾ with up to 3500 Nm of braking torque
- Seatbelt monitor
- Cab design according to ECE R29 and Swedish test VVFS 2003:29 regulations
- Driver airbags
- LED daytime running lights and LED tail lights



Robustness knows no compromises. The same goes for the new Arocs.

Loading capacity and robustness are crucial to economical transport operations on unsurfaced roads and off-road. The Arocs rises to the challenge here on every trip and in every situation.

The new Arocs – for more robustness. Trucks from Mercedes-Benz are particularly durable and tough operators. They continue to run without a hitch, even after years of demanding service. The Arocs has already proven these credentials in many countries. Alongside its uncompromising reliability, it also demonstrates extreme robustness. In keeping with the aim that our engineers pursued throughout the development process for the Arocs: it was to be ideally prepared for practically any challenge in required deployment.

For more robustness, there is the Arocs. Meaning you can go about your day-to-day tasks more effectively and efficiently whatever your line of work, whether it's grocery transport, retail supply services or tanker and dry-bulk haulage. This is all thanks to practical, comfortable cabs, responsive and dynamic powertrain configurations featuring fuel-saving robust engines, as well as extremely

safe, solid driving characteristics. This is backed up by low repair and maintenance costs, complete ease of body mounting and a diverse product portfolio. In short, a truck which points the way forward with enhancements that make it a truck ideal for distribution transport. First and foremost though, one which offers you a tailored, purpose-built solution for all distribution applications from 18 t upwards. The new Arocs. Climb aboard and experience the new class of truck in distribution.



Our Parts Offering.

Genuine Remanufactured Parts. Mercedes-Benz Genuine Remanufactured Parts cut costs without skimping on quality. In a thorough careful manufacturing process, each part is remanufactured, checked and tested in accordance with strict Mercedes-Benz standards. We pass the savings achieved from raw materials and energy on to our customers as a price advantage. The result is a wide range of Genuine Remanufactured Parts products that is constantly updated. For more information please refer to the downloadable product brochure or contact our nearest dealer.



Genuine remanufactured parts: Genuine quality comes at an affordable price. You are not forced to choose between price and quality when your Mercedes-Benz Truck with high mileage needs replacements parts.

GenuineParts. With Mercedes-Benz GenuineParts you benefit from more than one hundred years' experience in vehicle and parts manufacture. Thanks to their exceptional quality, approved safety and outstanding reliability, these parts are a compelling proposition. What is more, the extreme durability and price/performance ratio of our GenuineParts is particularly cost-effective. Precisely defined manufacturer's specifications plus comprehensive checks and tests guarantee that each and every Mercedes-Benz GenuinePart meets our highest quality standards and is always state of the art. Mercedes-Benz GenuineParts can be recognised by their unique hologram packaging.



Genuine Parts. With so much uncertainty about the road ahead you can look forward to 24 months of worry-free driving. That's because we're the first to offer our customers a standard 24-month, unlimited mileage warranty on all Mercedes-Benz Truck GenuineParts fitted in our workshop.

Mercedes-Benz Lubricants. Who better to buy oil from than the experts that built your engine? Mercedes-Benz genuine engine oil is specially developed and optimally matched for Mercedes-Benz engines. The high-performance additives used ensure optimum viscosity and ideal flow characteristics even in extreme temperatures. For more information please refer to the downloadable product brochure or contact our nearest dealer.

Reduced friction for greater performance. Oil reduces the mechanical friction, and our engine oil is able to cope perfectly with the mechanical and



Mercedes-Benz Lubricants.

thermal loads. The components and additives, which have been specially selected for it, meet the particular quality standards of a Mercedes-Benz engine, ensuring higher levels of efficiency and performance.

The special quality of Mercedes-Benz genuine engine oil gives you the clear benefit of economic driving. It lets you fully exploit your engine's potential in different driving conditions while using less fuel. Reduced emissions.

Working with our state-of-the-art exhaust gas after-treatment systems, our oil also helps to reduce the emission of toxins which are harmful to the environment. Reliability.

Even when subjected to thermal loads of heat or cold, Mercedes-Benz genuine oil shows no signs of evaporation loss, and maintains flow and lubrication characteristics while remaining 100 percent reliable to lubricate and perform all its other functions. Why choose Mercedes-Benz genuine oil? This is the only oil that is designed specifically for your engine, and it also has the unique property of lasting longer. If you change it at regular intervals together with your genuine filters you can ensure that your engine is working at a consistently higher standard.



Please note: changes may have been made to the product since going to press (01.10.2021). The manufacturer reserves the right to make changes to the design, form, colour or specification during the delivery period, provided these changes, while taking into account the interests of the vendor, can be deemed reasonable with respect to the purchaser. Where the vendor or the manufacturer uses symbols or numbers to describe an order or the subject of an order, no rights may be derived solely from these. The illustrations and texts may include accessories and items of special equipment which are not part of standard specification. Colours may differ slightly from those shown in the brochure, owing to the limitations of the printing process. The images shown are to be considered examples only and do not necessarily reflect the actual state of the original vehicles. The appearance of the original vehicles may differ from these illustrations. Subject to change. This publication may also contain models and services which are not available in certain countries. This brochure is distributed internationally. It provides a general indication of the range of models, features, special equipment and/or colours available in various countries. Some of the models, features, special equipment and/or colours may not be available in your country, or may only be available in a different specification. Additionally, some models, features, special equipment and/or colours may only be available in combination with others. For current and more specific information in relation to the range of models, features, special equipment and/or colours available in your country, and their pricing, you should contact your nearest authorised **Mercedes-Benz Truck dealer**. www.mercedes-benz.co.za/trucks

Daimler Trucks and Buses Southern Africa.