



# The Unimog.

U 4000/U 5000.

Mercedes-Benz

Trucks you can trust.







# The Unimog concept.

Getting through where others give up.

Where even four-wheel drive trucks reach their limits, a totally different kind of work and tractor vehicle has to take over: the Unimog. It gives a new definition of versatility and viability on four wheels. The Mercedes-Benz Unimog is a vehicle in a league of its own. It provides solutions which no other vehicle worldwide can offer. The Unimog is more versatile than any other with its attachment and mounting areas at the front, middle and rear. It is also more at home on off-road terrain than any other vehicle, and can drive at fast speeds on roads as a transporter. The Unimog is an uncompromising professional for uncompromising professionals. Superior in every situation and over any terrain.

## Contents.

Off-road capabilities	4-9
Attaching and mounting areas	10-11
Easy to operate and ergonomic	12-15
Economic efficiency and the environment	16-17
After-sales service and financial service	18-19

## Off-road capabilities.

With its unique off-road capabilities, the Unimog U 4000/U 5000 beats every rival. Worldwide. Its outstanding features make sure of that: its flexible frame for great rigidity on the road and great torsional flexibility off-road; its superior chassis expertise with engageable four-wheel drive, differential locks in both axles, reduction gears for off-road as well as portal axles for particularly high ground clearance. Whether deep snow, high water, bogs or scree – the Unimog takes its crew, materials and heavy equipment quickly and safely to any location. The Unimog is always in the front line to bring help for disaster intervention or for expeditions.





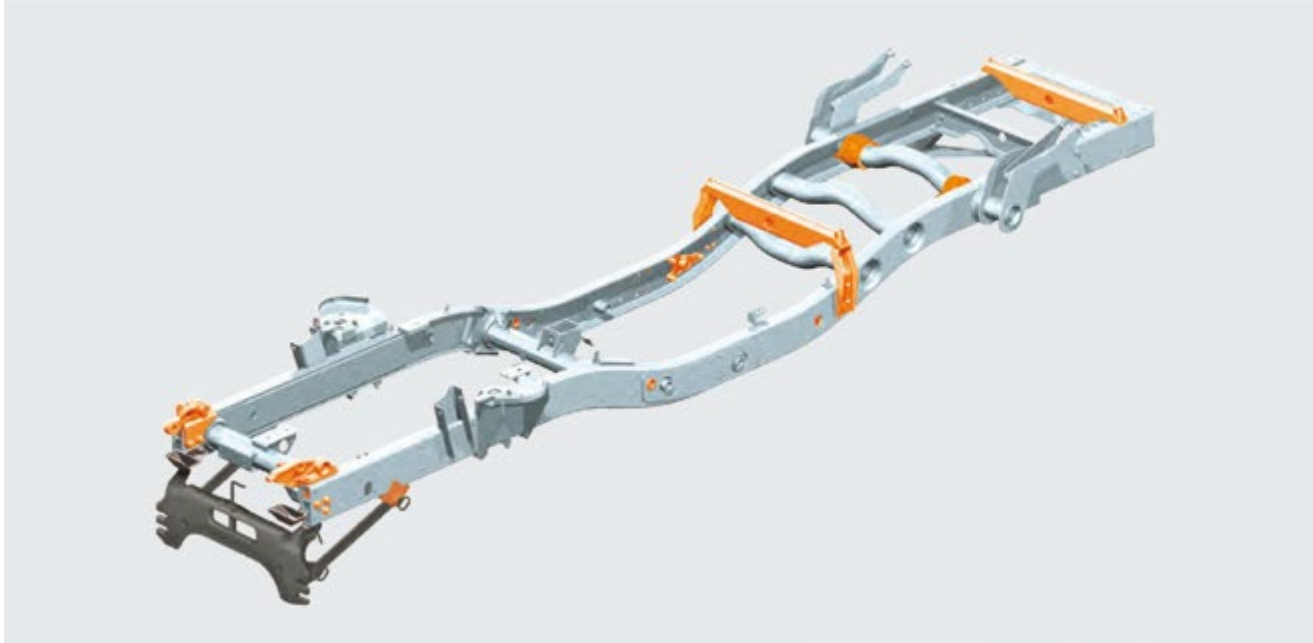

High ground clearance with portal axles and wheel-hub drive.

**Flexible frame design.** It gives way, when and where required. At the heart of the uncompromising all-terrain capabilities of the Unimog U 4000/U 5000 is the flexible frame with tubular cross-members which ensures the necessary rigidity on the road, and allows great torsional flexibility off-road. This is provided by the three-point mounting of cab, engine and transmission, as well as the defined interfaces for mounting superstructures and implements. This means that even axle articulation of up to 30° is possible.

- Highly resilient offset frame for a low centre of gravity and high driving stability off-road
- Short frame overhang for steep angles of approach or departure
- Safe and controlled driving in any situation

**Portal axles.** Extreme off-roading made easy. Portal axles are the secret behind the outstanding ground clearance of the Unimog U 4000/U 5000 - it copes with impassable terrain and obstacles up to half-a-metre high. A reduction gear on the wheel-hub drive allows the full torque to take effect on the ground for increased traction over difficult terrain.

- Outstanding ground clearance with a low vehicle centre of gravity
- Axle tube and differential are clearly smaller than on a truck and are situated above the wheel centre
- Differentials installed outside the centre of the axle guarantee high ground clearance even on tracks with deep ruts

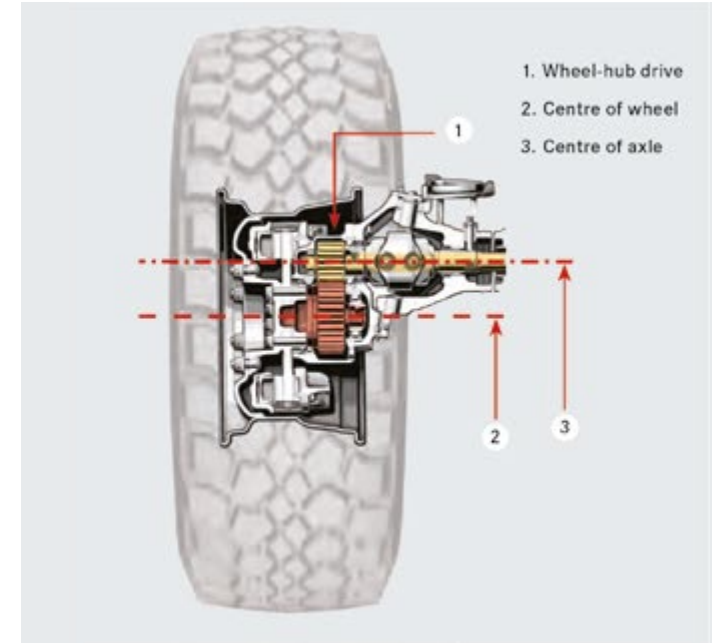

Ample ground clearance due to two identical portal axles with wheel-hub drive.

**Axle suspension.** Keeping all four wheels firmly on the ground. One advantage off-road is the axle suspension with thrust tube, control arm and coil springs. This somewhat unusual type of suspension for an off-roader provides long spring travel and outstanding axle articulation. Stabilisers at front and rear ensure high cornering stability and safe driving.

- Permanent surface contact for all four wheels, even over extremely uneven ground
- Progressive spring characteristics ensure driving stability with any load
- Very safe driving, even with bodies with high centre of gravity

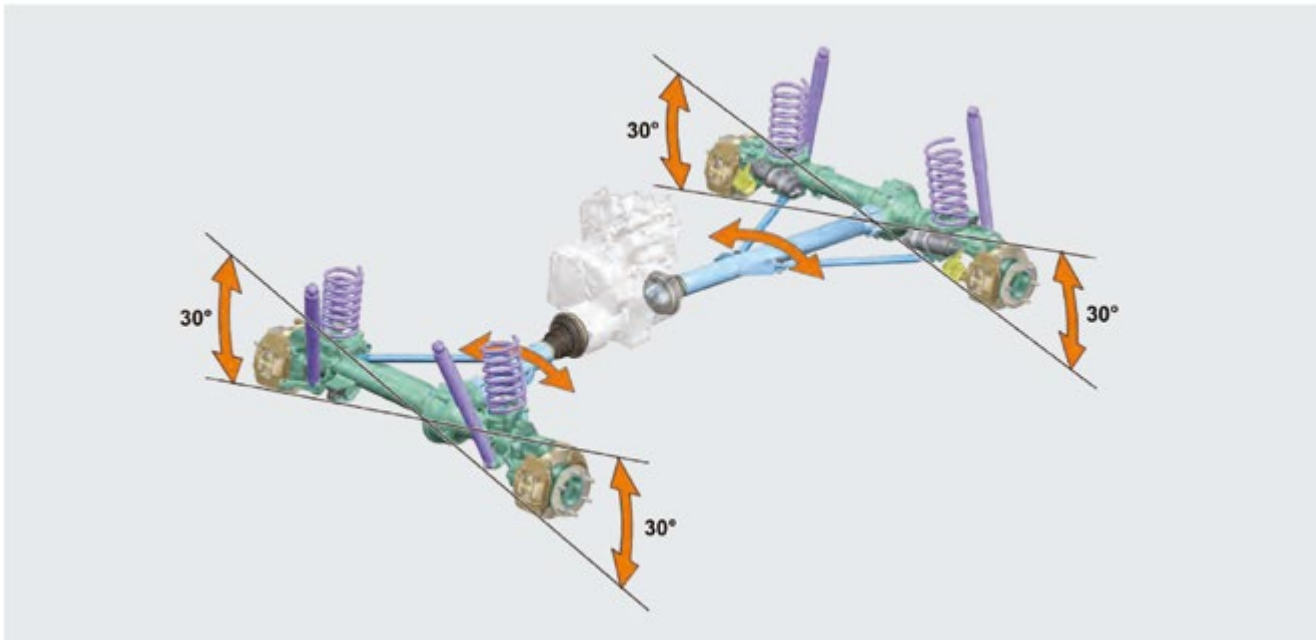

Axle suspension with coil springs and thrust tube technology guarantee long spring travel and maximum axle articulation.

**Thrust tube technology. Greatest possible diagonal torsion.** The special thrust tube construction gives the springs extremely long travel and permits diagonal axle articulation of up to 30°. As the thrust tube encloses the drive shaft, it is safe from dirt and damage.

- Extremely long spring travel
- Maximum diagonal torsion
- Drive shaft protected over extremely muddy and rocky terrain
- Wear-resistant and maintenance-free axle suspension

**Manually engageable four-wheel drive. Powerful – off and on the road.** With its rear-axle drive for driving on roads and the manually engageable four-wheel drive for off-road work, maximum traction is available in every situation. And, over extremely difficult terrain, differential locks in both axles make sure the powertrain is working at full strength. Even if only one wheel has sufficient traction, the Unimog still gets ahead and copes with gradients of up to 100%.

- Selectable rear-axle drive or four-wheel drive
- Differential locks at front and rear engaged or disengaged with rotary switch while driving
- No interruption of tractive force during gear shifting
- All four wheels synchronised 100% by locking effect in both axles



Even over extreme terrain, the Mercedes-Benz Unimog always has all four wheels firmly on the ground.

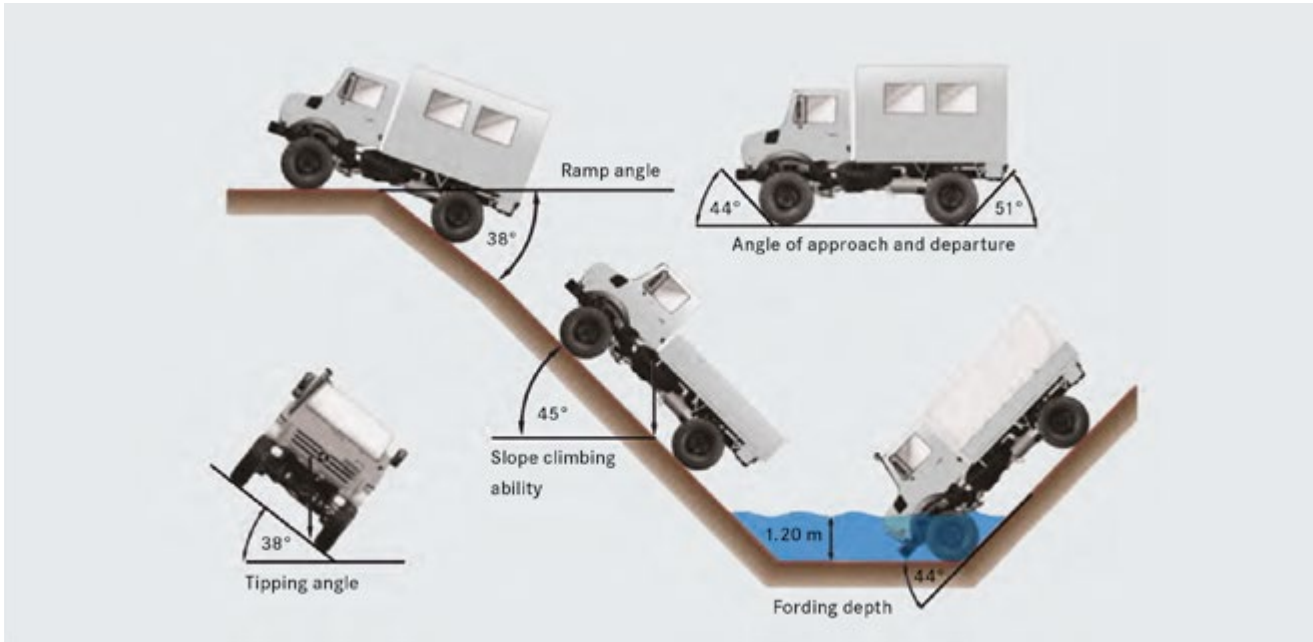

Safe over any terrain with large angles of approach or departure at front or rear, climbing ability up to 100% and fording ability to a depth of 1.20m, the Unimog gets you to any destination.

**Short frame overhang. With ease over difficult terrain.**

Thanks to its coil springs with long spring travel (instead of the typical leaf springs used by trucks), the Unimog U 4000/U 5000 has a short frame overhang at front and rear, enabling it to tackle steep ramps and embankments with ease. Its low centre of gravity and extreme torsional flexibility provide additional security with respect to steep slopes and tipping angles.

- Overcomes obstacles, hilltops, steep slopes or embankments easily

**Fording ability. Not at all shy of water.** Watercourses or flooded areas are not a problem for the Unimog. Thanks to its thrust tube technology, air intake pipe at cab roof height and waterproofed components, the standard version can ford 80cm of water. And with the optional fording package, it makes its way through water up to 1.20m deep, arriving safe and dry on the other side without any damage from water or fine sand seeping in.

- Able to ford water up to 1.20m deep
- Special seals protect all important components against penetrating water or moisture and dirt



Even when fording, sensitive units and electrical installations remain high and dry.

**Single tyres. For anywhere and everywhere.** Unlike the normal four-wheel drive trucks with twin tyres fitted on the rear axle, the Unimog has four single tyres. The rear wheels always run in the compressed tracks created by the front wheels, which offers higher traction and lower rolling resistance. With the wide range of tyre sizes and types available, the Unimog can be equipped with exactly the right tyres for the terrain in question.

- A large selection of tyres are available: from MPT low-pressure tyres to special sand and high-traction tyres
- Chains can also be used for snow or difficult terrain, depending on the size of the tyres chosen



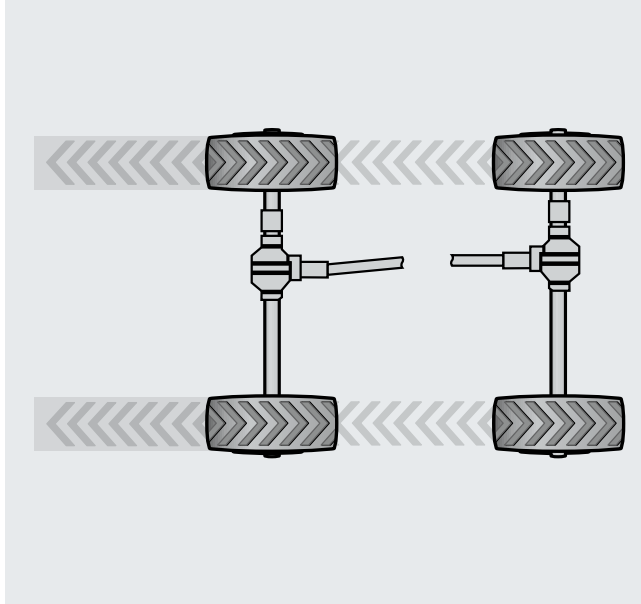

The single tyres increase driving stability and traction and have low rolling resistance.



With Tirecontrol you can adjust the tyre pressure to suit the terrain – simply with a switch.

**Central tyre inflation system (Tirecontrol). Always the right tyre pressure.** A further plus when driving over challenging or soft terrain: Tirecontrol, the optional system for adjusting tyre pressures quickly and flexibly to suit changing surface conditions while on the move. The air pressure is lowered at the touch of a button in the cab to increase the tyre contact area, thus preventing it from sinking into soft ground and to increase traction.

- High traction, good self-cleaning properties and reduced tracks on the ground
- Flexible adjustment of tyre pressure while driving to suit the road and terrain conditions
- Longer tyre life owing to always-optimal tyre pressure
- Avoidance of soil compaction and damage to the environment thanks to low tyre pressure

**Dual-circuit braking system plus ABS and ALB. Safe in any situation.** The compressed-air-supported dual-circuit disc braking system always brings the Unimog to a safe stop, even on long hills and with heavy loads. It is just as reliable in winter as it is in summer after driving through mud and water. Additional safety and driving stability are provided by the disengageable anti-lock braking system (ABS) as the wheels can then block and shorten the braking distance in difficult terrain by building up a soil wedge.

- Effective spring-type parking brake requiring minimal operating strength
- ABS control for each wheel
- ALB – automatic braking force control which adjusts to the load situation

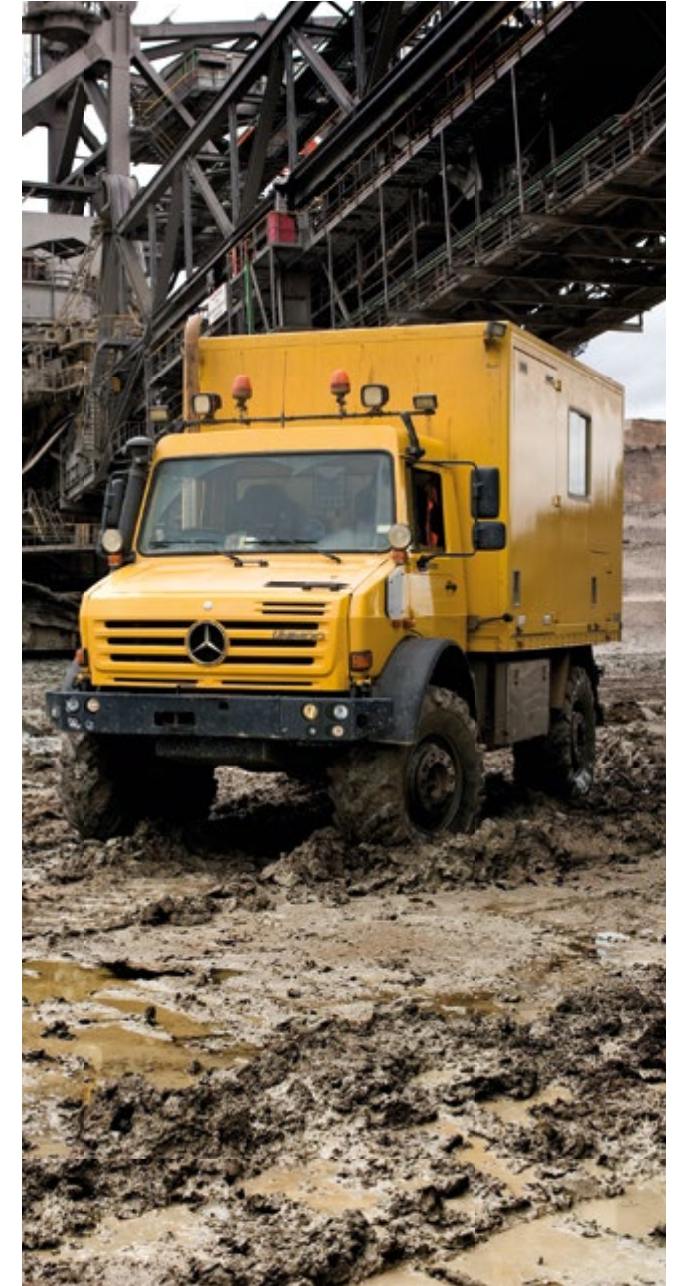

Disc brakes and disengageable ABS on all four wheels provide greater safety off-road – even when loaded with heavy superstructures.

## Attaching and mounting areas.

One for almost everything - with its two attaching areas and one mounting area, the Unimog U4000/U5000 is a unique vehicle with outstanding off-road capabilities for very varied operations far away from paved roads. For year-round use and very cost-effective.



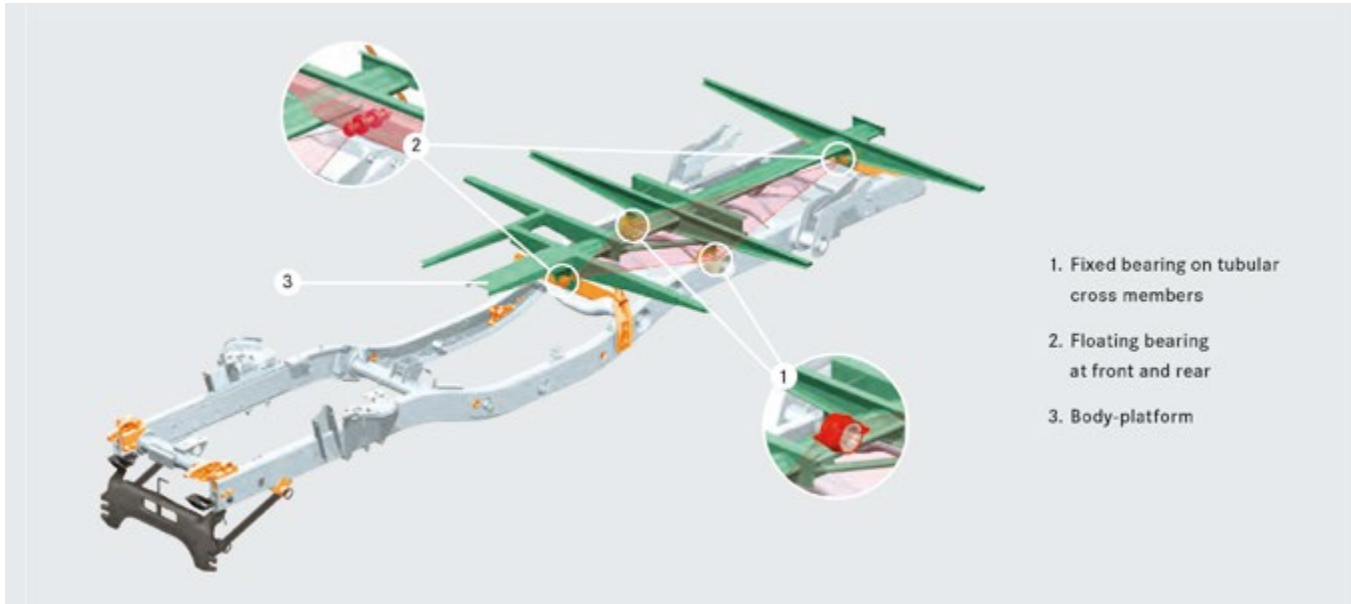

Twist and strain-free mounting of sensitive units and superstructures due to double three-point mounting.

**Double three-point mounting. Outstanding off-road capabilities even with superstructures.** In addition to the 3-point mounting for cab, engine and transmission, the heavy-duty frame is also fitted with a double three-point mounting system to ensure twist and strain-free mounting for superstructures. They are fitted at positions best suited for passing on thrust, traction and weight forces. The three-point mounting decouples the cab from the superstructure so that the vehicle always remains torsionally flexible and can keep moving even in the most extreme off-road conditions.

- **Frame with double three-point mounting system for superstructures**
- **Optional ex works: sub-frame with double three-point mounting and integrated mounting positions for easy fitting of box-type superstructures and supporting frames for heavy superstructures like cranes**

**Attachment and mounting areas. Close cooperation with body and implement manufacturers.** Where great demands on man and technology meet up with extreme terrain, the Mercedes-Benz Unimog comes into its own. And thanks to its great versatility and individuality, the demands of the job can be met. For decades, implements and bodies have been designed in close cooperation with leading manufacturers. And you can rest assured that in the long run, you will be getting the perfect solution for your vehicle or special operation.

- **Front mounting area: brackets for attaching front winches**
- **Mid mounting area using mounting points or sub-frame: minimal stress and strain, long life span for vehicle and implements**



Commercially-available hydraulic pumps, e.g. for a crane, can be used via a standardised connection on the manual transmission.

**Auxiliary drives. Including all power options.**

The Unimog U 4000/U 5000 has an auxiliary drive for running commercially-available hydraulic pumps for cranes or excavators. It also has a fast auxiliary drive for connecting to fire-extinguishing pumps or similar power units.

- **Operated via a pull switch in the centre console**
- **Hydraulic or fire-extinguishing pumps controlled via a special CANbus-linked module with programmable parameters**

**Hydraulic system. Simple to connect, easy to operate.**

This powerful hydraulic system with a working of up to 240 bar can run an oil engine or an external control panel, making it suitable for both permanent consumers and for operating implements via valves on the piece of equipment. Standard plug connections make for easy, fast and error-free connections.

- **Two hydraulic connections each at front and rear (pressure and return line) for winches, cranes, etc.**

## Easy to operate and ergonomic.

The cabs of the U 4000/U 5000 provide everything the driver and crew need to do their everyday work as ergonomically and safely as possible.

The interior with its sound-absorbing panels and comfortable seats is equipped with generous storage areas and headroom (e.g. when wearing a helmet).

The cab floor is flat through-out, ensuring free through-cab access.

And a pleasant working atmosphere is always ensured by the integrated air-conditioning unit and the auxiliary heater.



**Short-bonnet cab. Spacious and ergonomically designed.**

The position of the cab behind the engine together with its three-point mounting on rubber elements reduces vibration and jolts and provides a relaxed working atmosphere even if the job on hand lasts a long time. Available as an option: luxury seats with seat-heating and back supports for the lumbar region make working a pleasure. The good visibility from the short-bonnet cab and its good handling are also a great advantage especially when working off-road in rough country.

- Cab: three-point mounting to neutralise vibrations
- Optional: round swivel roof hatch
- Square fresh air flap that can be raised to all four sides
- Easy entry and exit behind the front axle
- Driver's position behind the front axle for better ergonomics, better visibility and optimal off-road driving qualities

**Compact dimensions.** The low overall height of the standard driver's cab is optimal for passing under low structures, e.g. in smaller fire stations and vehicle sheds.





Spacious crew cab accommodates up to seven persons, or, as an option, it is available with four individual air-sprung seats.

**Crew cab:** Ideal for task forces and crews: the Unimog U 4000/U 5000 with the special version crew cab providing enough room for seven people as well as maximum legroom and headroom. Also, four air-sprung individual seats are an available option. Generous storage space is available in the three large compartments under the fold-away rear bench. Tools, work materials and personal equipment of all the crew members can be stored here safely, but are still easy to access at any time. Other storage compartments are on the central console and in the front doors. The rear passenger doors open extra-wide making it easier to get in and out. A further plus: the additional roof hatch at the rear.

- **Optional:** crew cab with raised roof, four side doors, up to seven seats integrated in the vehicle's design; available ex works
- Plenty of storage space under the fold-away rear bench
- **Optional:** four individual air-sprung seats



Plenty of space for tools and personal equipment under the rear bench.



The instrument panel is clearly structured with an easy-to-operate driver information system, backlit dials and two LCD multifunction displays.

**Ergonomic. Clearly arranged and easy to operate.**

The driver information system (FIS) allows all important functions to be checked at a glance with status reports, event reports and menu-driven online diagnosis. The standard cruise control, Temposet, electronic manual throttle control and the two-stage engine or permanent brake are all controlled with the multifunction lever on the right-hand side of the steering column. Optical and acoustic signals help the driver to react immediately if the need arises. The radio/CD player combination with Bluetooth interface and hands-free facility enhances operating safety.

- Cruise control regulates the speed without the accelerator
- Temposet limits the speed with the accelerator
- Manual throttle control sets an exact engine speed

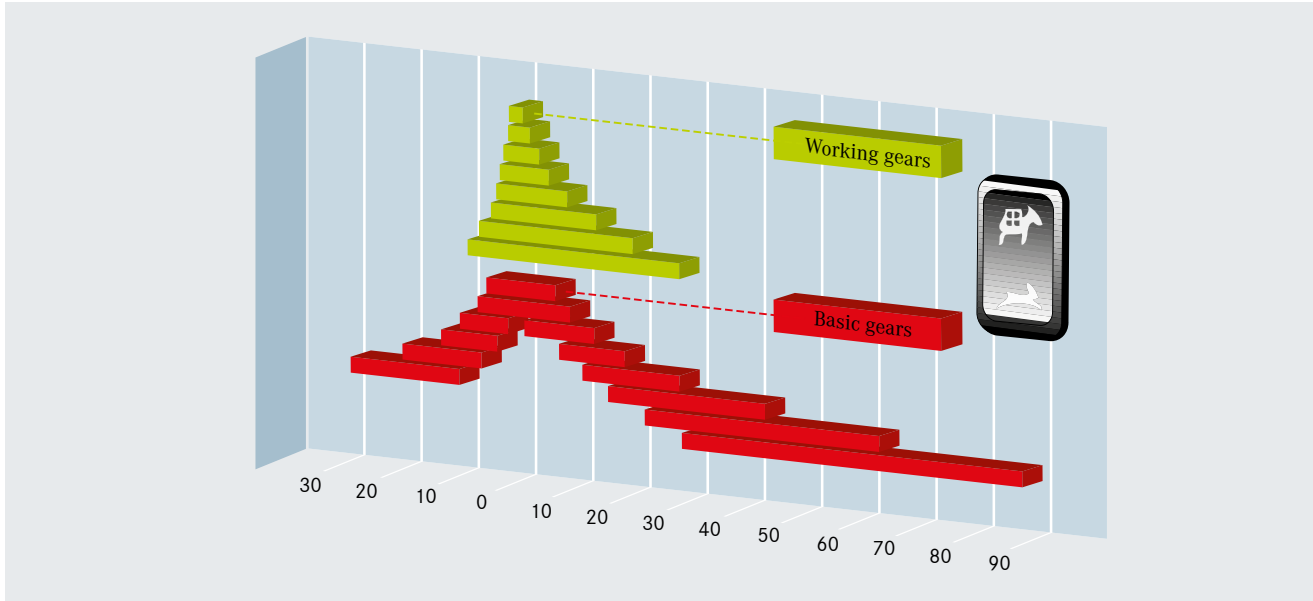

With its finely graduated speeds and as an option fully load-bearing off-road gears, the Unimog U 4000/U 5000 is perfectly equipped to deal with very varying operations.

**Telligent® gearshift. Shifts in a flash.** Tap the gearshift lightly to front or rear – and the shift control will instantly calculate the torque and, depending on the engine speed, the appropriate gear to engage, which is then shown on the display. If you agree, you only have to press your clutch. Otherwise, simply select the gear you want manually.

- Easy on the engine, clutch and transmission
- Relaxed, concentrated and economical driving

**AutomaticShift. Shifting gears as you like.** Take the strain out of driving while operating implements or hauling heavy loads. With AutomaticShift you can decide, at the touch of a button, to use either “M” for manual or “A” for automatic gearshifting. Both without using the clutch. Even in automatic mode, the driver can intervene with the gearshift lever and change a gear manually.

- Less wear and tear on the clutch
- Reduced fuel consumption
- Select either automatic mode (e.g. for driving on the road, concentrating fully on the traffic) or manual mode (e.g. for off-road driving, for complete control of your vehicle)



Electronic Quick Reverse makes it easy to change directions quickly or rock free off-road.

**Transmission. As versatile as you need it to be.** The fully synchronised electro-pneumatic gearshift Telligent® with its eight forward gears and six reverse gears stands out with its smooth-running, long life span and high efficiency. It is perfectly coordinated to deal with numerous types of operations. The synchronised Electronic Quick Reverse (EQR) makes it easy to change directions quickly or to rock free when off-roading. The special off-road gear group with an additional eight forward and eight reverse gears guarantees maximum traction in the lower 1-15km/h speed range.

- For every situation the proper gear: efficient and cost-effective
- Direct, rapid gear shifting, e.g. to rock free off-road

## Economic efficiency and the environment.

The Unimog U 4000/U 5000 is not just ready for any situation or terrain, it is also designed for a long cost-effective working life. Reliability, a long life span, economic efficiency and environmental protection make the unique implement-carrying concept an unrivalled future-proof vehicle.

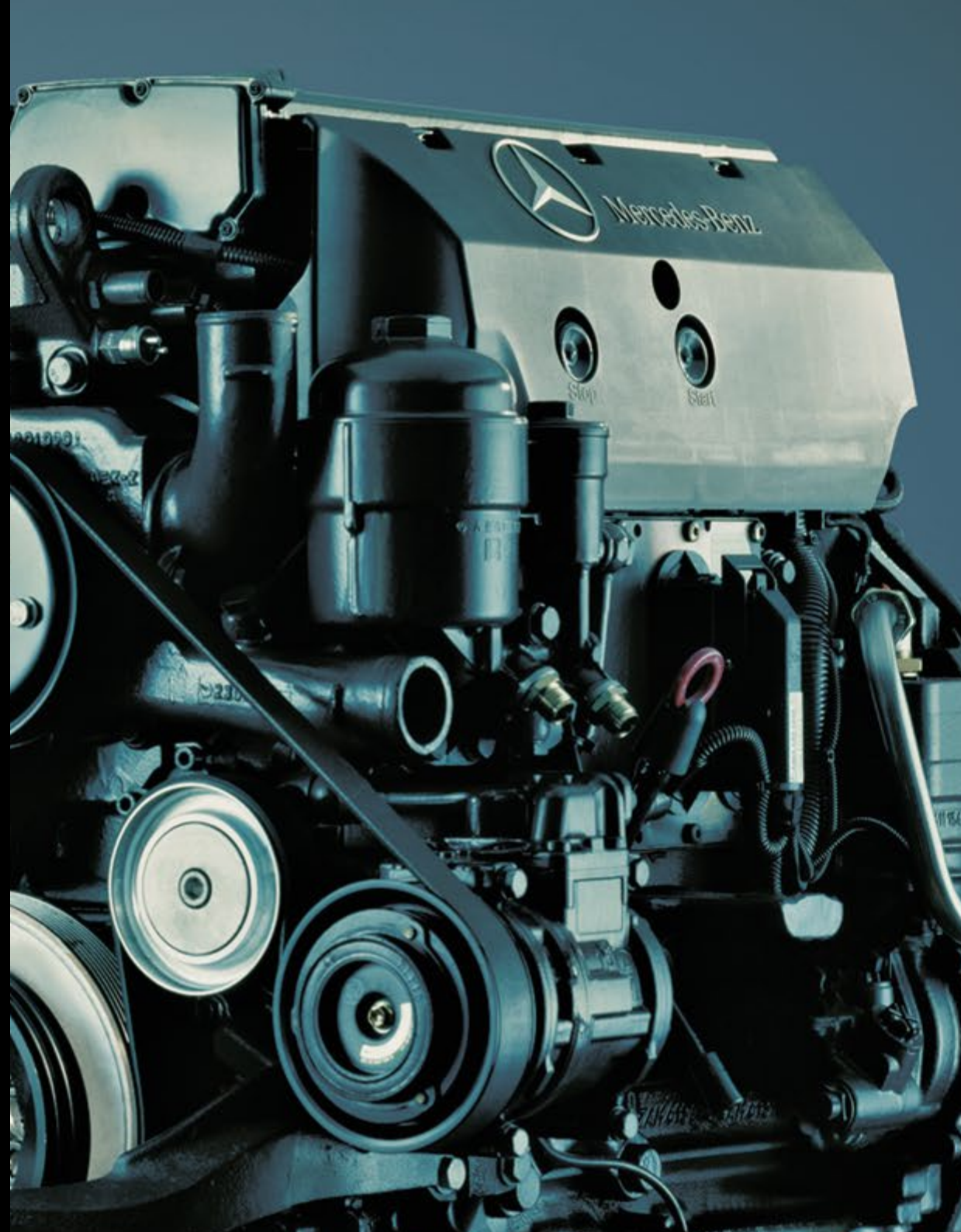



**Mercedes-Benz engines. Always ready to give peak performance.** The low maintenance four-cylinder engines from Mercedes-Benz are state-of-the-art in every aspect and perfectly equipped to fulfil any and every assignment. From their direct-injection and three-valve technology, turbocharger and intercooler, to their steep torque curve, constant output over a wide rpm range and high power reserves, the combustion-air intake is positioned on the cab roof where dust levels are lowest. The radiator system has been developed especially to cope with the high demands placed on the Unimog U 4000/U 5000. Intercooler and radiator, each with its own viscous fan, are fitted next to each other high above the ground. Thus, the cooling performance is greatly improved and the danger of fouling is kept to a minimum for maximum functional safety when fording. You can definitely rely on the Unimog to get you through, even during the most demanding off-road operations involving extremely varying temperatures or extreme dust.

- From 130kW to 160kW
- Low-emission, economical and quiet-running
- Great tractive force and good torque rise

**BlueTec®: clean, safe, economical.** BlueTec® drastically decreases nitrogen oxide and particulate emissions while optimising fuel consumption without reducing diesel engine performance, and without needing a particulate filter. A catalytic converter reduces the nitrogen oxide with the additive AdBlue, a chemically non-toxic, aqueous urea solution which is added from a separate tank. With this technology, the Unimog not only meets the strict European Union standards to reduce vehicle emissions, it also provides a system with minimal wear and tear and maintenance, improved engine performance – depending on the version –

## Uncompromising Clean with Euro 3/Euro 5.

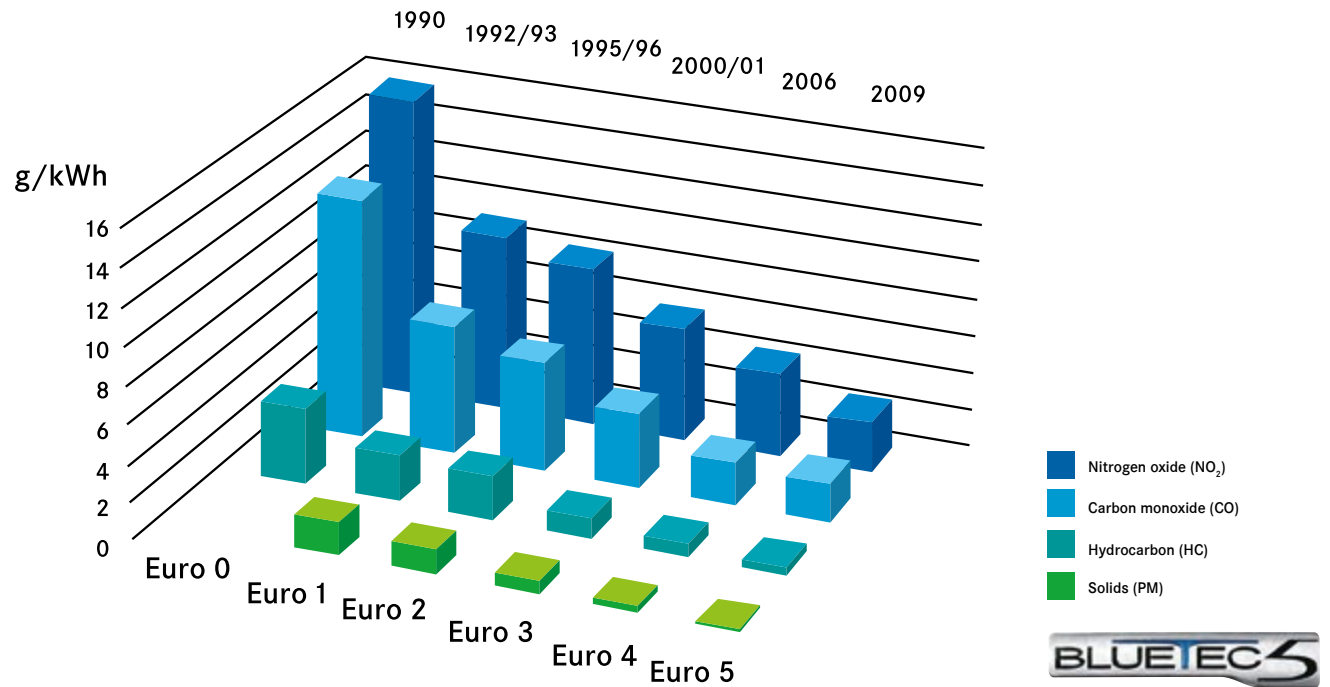

and, thus, a future-proof solution. Where the Euro 5 emission standard is not binding, the Unimog continues to be optionally available in Euro 3 version and, even with that, already meets a high environmental standard for emissions.

- Euro 5 - compliant with diesel particulate filter
- Depending on national emission standards, the Unimog is available in Euro 3 or Euro 5 versions

**Driving and working modes. Engine regulation as needed.** Engine modes individually adjustable depending on the job. The elasticity of the engine speeds in the driving mode is ideal for road trips and transports. The working mode guarantees minimal engine speed deviations, e.g. for off-road trips even with varying loads.



After-sales service.

We are there, wherever you are.

The Unimog will take you anywhere you want to go – and that is why we are also everywhere for you. At our 650 Mercedes-Benz Service Centres worldwide we can see to your Unimog – if necessary at once. Using just the same care, the same experience and the same technical expertise we used for its construction. And of course, using only spare parts which comply with our strong standards concerning quality and availability.

#### Your advantages at a glance:

- ✓ Service network worldwide
- ✓ Personal and flexible after-sales service
- ✓ After-sales service directly from manufacturer to customer
- ✓ After-sales service for both vehicle and implements
- ✓ Customised service products
- ✓ High quality and readily available Mercedes-Benz GenuineParts

Financial services.

Customised solutions to suit your requirements.

Your success relies on a professional financing concept for your fleet. Just like your vehicles, your capital should always be readily available. And that is where the Unimog system with its financial services can make a considerable contribution. We can offer you economically efficient financing and leasing models at favourable conditions which are individually designed to suit your needs.

#### Your advantages at a glance:

- ✓ Reasonable conditions
- ✓ Flexible terms
- ✓ Guaranteed interest rates
- ✓ Individual advisory services
- ✓ One-stop service from your Unimog partner



Want to get things moving? You have gotten to know the Unimog U 4000/U 5000 in this brochure. As a professional implement carrier over 11.99t max. weight, the Unimog U 400/U 500 provides unrivalled top performance. Especially for professionals who want to combine outstanding performance with economic efficiency in year-round service.

**Do you have any questions, comments or suggestions on the topic of Unimog? Or want to know what the Unimog can do for you? Then don't hesitate to contact us. We are looking forward to hearing from you!**

**Concerning the details in this brochure:** the products may have undergone slight changes after the editorial deadline of this brochure. We, the manufacturers, reserve the right to make any constructional changes, design alterations, colour modifications as well as changes to the scope of delivery during the delivery period, as long as the changes or modifications are not unreasonable for the customer. The salesman and/or manufacturer are not legally bound as long as they describe the order or the ordered articles with symbols or numbers. The pictures in this brochure may also contain accessories or special fittings that do not belong to the standard scope of delivery. Colour modifications are due to topographical causes. This printed matter may also contain models and customer services that are not available in individual countries. Statements concerning statutory, legal and tax regulations and the implications thereof are only valid for the Republic of South Africa prior to the deadline of this brochure. Please consult your Unimog Partner with respect to the latest binding regulations and stipulations and their implications.

[www.mercedes-benz.com](http://www.mercedes-benz.com)

A 102UNI08 17 0002